

# 7FB

ELECTRIC POWERED FORKLIFT

1.0 to 3.5 ton

SERIES



 **TOYOTA**

**AC** Power System and **SAS** Provide

# Trend-Setting Style and Performance

Just a glance tells you that the 7FB is distinctly different than any other electric forklift you have ever seen. And that difference is more than just appearance.

The 7FB is the first Toyota electric forklift to harness the benefits of AC Power and the System of Active Stability (SAS). This trend-setting 7FB is a major leap in the evolution of the electric forklift design and another shining example of Toyota's continuing quest for excellence.





**Fatigue-Fighting  
Comfort**

**Full-  
Control  
Operability**

**Productivity-  
Boosting  
Control**

**State-of-  
the-Art  
Safety**

Features and equipment may vary depending on market.

# Fatigue-Fighting Comfort

AC power also makes a big difference in enhancing operator comfort. AC motors are more compact than DC motors, and this difference in size gives engineers more design freedom. By using this freedom and relocating the battery under the floorboard, Toyota has opened the 7FB to a wide range of comfort-enhancing features for reducing operator fatigue.

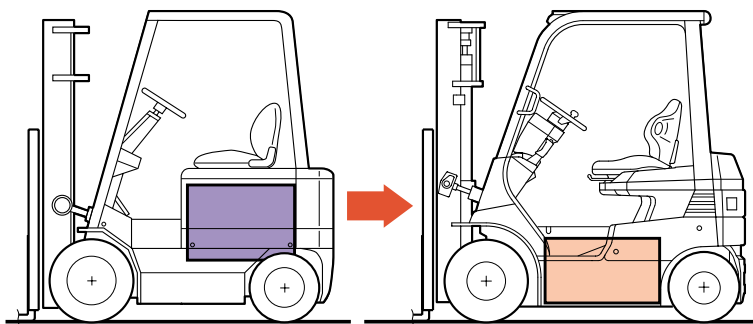

## Battery Layout

Powerful yet compact AC motors allow the battery to finally leave its conventional location under the operator's seat.

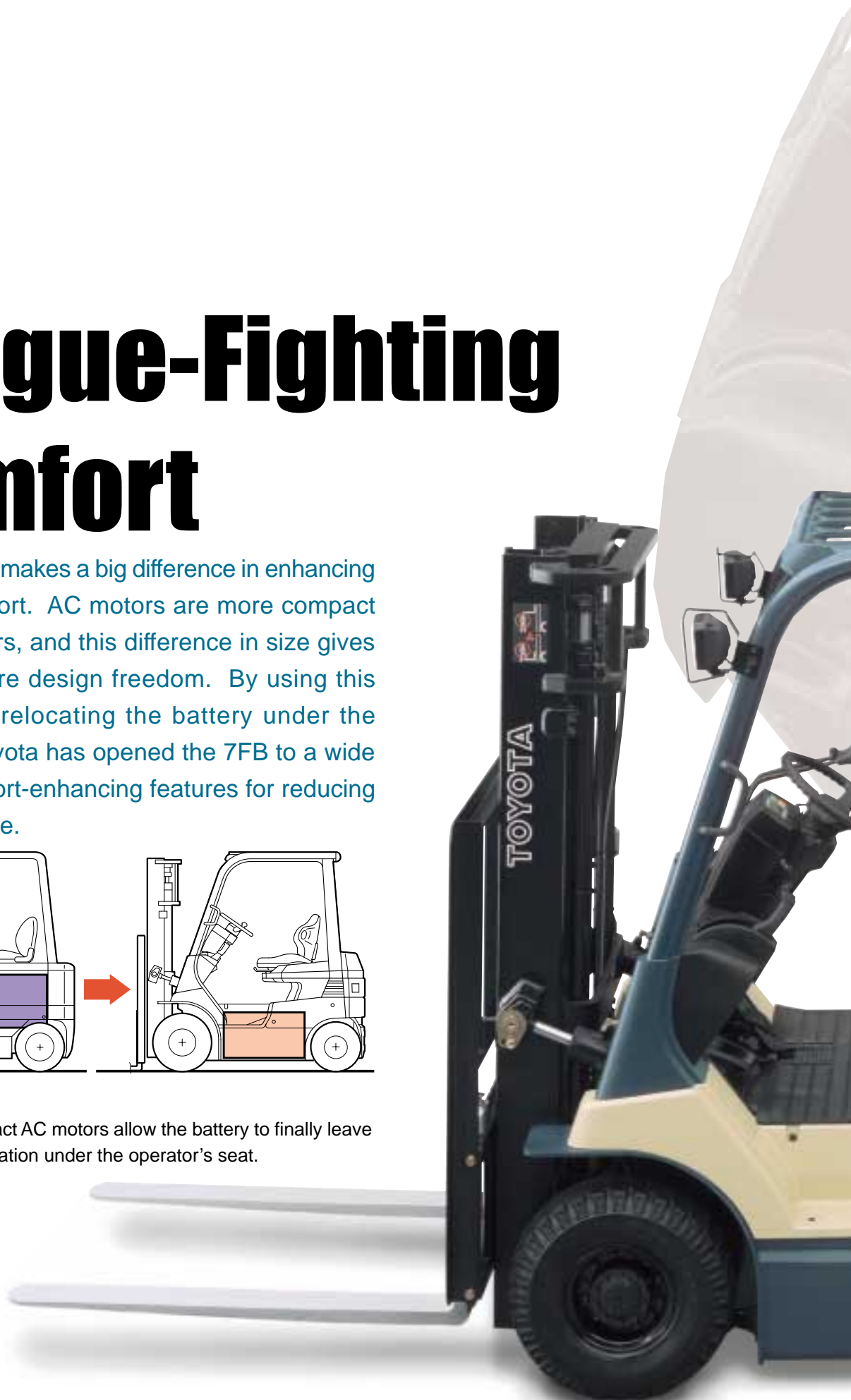

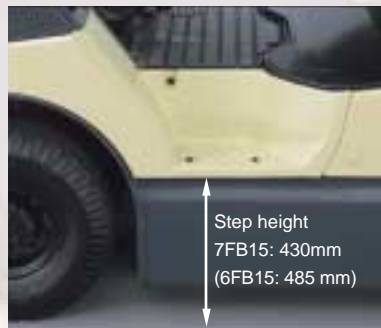

### Low-Height Step

Easy entry and exit thanks to the strategically located battery. This will be much appreciated by operators who have to get on and off of the forklift frequently.

### Expanded Leg Space

Designed to provide plenty of space to enhance the operator's freedom of movement and reduce fatigue. Covers at the bottom of the instrument panel and over the tilt cylinders add to the styling.



### ORS Seat

Operator Restraint System (ORS) seat contributes to comfort and security. Side wings and a retractable seat belt help keep the operator in place. The ORS seat can be adjusted longitudinally 120 mm. Its durable seamless covering resists tears and repels water.



### Ergonomic Driving Position



Easy to reach and operate controls mean maximum efficiency from minimal effort.

In addition, the operator's compartment is designed to provide plenty of head clearance and other space.

# Full-Control Operability

Toyota puts full control at your command. The steering wheel will tilt to meet the natural driving position of the operator. Control levers and switches are positioned within the normal range of motion and require minimal effort. All levers and switches are positioned for easy operation. The 7FB seems to be controlled by the mere wishes of the operator. Features such as SAS-Automatic Fork Leveling Control and the EHPS & SAS-Active Steering Synchronizer help enhance operability even more.

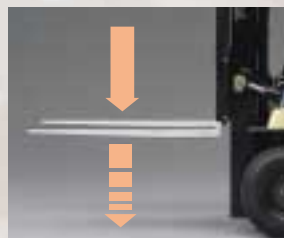

## Easy-Down System

Less noise and impact are provided by this system that gradually slows the empty forks just before they contact the ground. The operator and those working near the forklift will appreciate the reduced noise. (Standard equipment on V and SV masts.)

## Tilt Steering with Memory Device

Tailors the forklift to the operator. Adjusts to any position within a 13 degree range. The steering wheel tilts out of the way to accommodate battery changes, but can be automatically returned to its original position.



## Direction Lever

Finger-tip operation can be performed while the hand is still on the steering wheel. Its electronic design provides easy operation along with fast and accurate direction selection. (Note: Picture shows optional right-hand direction lever.)



Features and equipment may vary depending on market.



### SAS-Automatic Fork Leveling Control

Level fork position provides easier fork insertion and extraction, helping to boost overall productivity. Simply press a button on the tilt lever when moving the mast from the rear-tilt position and the forks will automatically stop at the level position.

### EHPS&SAS-Active Steering Synchronizer

Superior maneuverability is provided by the linkage-free Electronically-controlled Full Hydraulic Power Steering (EHPS). This design allows the rear tires to be turned to 100% of their full turn angle while the forklift is stopped. The SAS-Active Steering Synchronizer maintains a constant relationship between the steering wheel position and the turn angle of the rear steer tires.

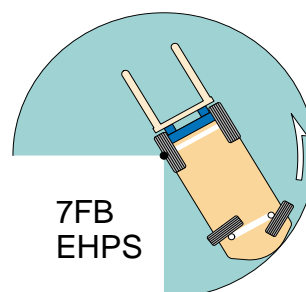

7FB  
EHPS

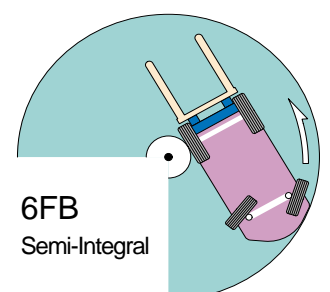

6FB  
Semi-Integral

# Productivity-Boosting Control

The AC power system sets the stage for levels of control unavailable until now. Changing travel direction is now smooth and fast. Both acceleration and deceleration are easy to control. Standard features such as Power Select Function and Power Keep Function help customize the 7FB to the task and make it even more efficient. All of these advancements are focused on redefining the meaning of forklift productivity.

## AC Power System

Multiple benefits of the AC Power System include: fast response to operating commands, precise power control, compact components. Moreover, since the AC motor does not use contactors and brushes, these maintenance items will no longer be required. It also allows for a revolutionary new forklift design and performance so enhanced the operator can actually feel the difference.







## Digital Multifunction Display

At-a-glance monitoring of the status of key operational information can easily be performed with the Digital Multifunction Display. It is also used for making settings, such as for the power control functions, and includes a diagnostic function for the electrical and other systems.

## Power Select Function

Customizes forklift performance to workplace needs. Both travel and load handling performance can be fine-tuned to match the conditions in the workplace and the skill of the operator.

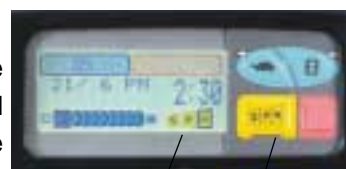

Indicator      Switch

### Battery Discharge Level and Performance Level

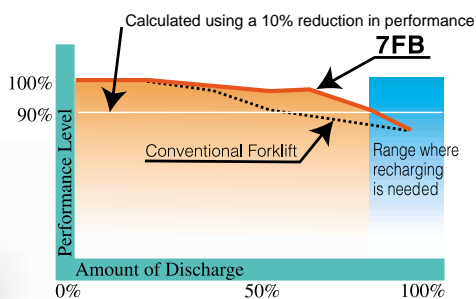

Note: Does not function in H-mode.

## Power Keep Function

Boosts performance when the battery charge is low. This control extends the efficient performance time of the forklift. Now the forklift can continue to work at top efficiency even when the battery charge is getting low.

## Three Types of Regenerative Systems

### When accelerator is released

Regenerative braking operates when the accelerator pedal is released during travel to collect the electrical power created. It also acts much like "engine braking" to slow the speed of the forklift.

### During switch back

Regenerative braking operates during travel whenever the direction lever is switched from forward to reverse (or vice versa).

### During braking

Regenerative braking operates whenever the brake pedal is depressed during travel.

The regenerative system also helps to reduce brake lining wear and helps extend operating time per charge.

Features and equipment may vary depending on market.

# State-of-the-Art Safety

The 7FB is loaded with features that show Toyota is always caring about the safety of the operator. Features provided by the System of Active Stability (SAS), such as the Active Control Rear Stabilizer and Active Mast Function Controller, are all aimed at reducing the consequences of operator error. The Toyota 7FB Series. Leading-edge computer-controlled safety that satisfies even the most experienced operators.

## SAS- Active Control Rear Stabilizer

Controls lateral stability when turning. This system incorporates a swing lock cylinder and a controller to prevent the rear axle from moving up and down during sharp turns.

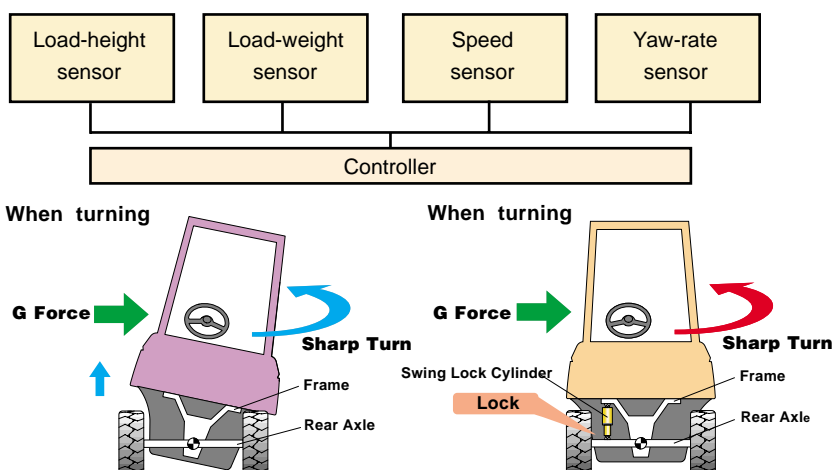

Features and equipment may vary depending on market.



## 2-Speed Travel Speed Control

Perfect for locations with different speed zones. The slower speed can be set to any speed between 5 and 12 km/h and this speed cannot be exceeded, even if the accelerator is fully depressed. The operator simply presses a button to restore the full maximum travel speed of the forklift.

## SAS-Active Mast Function Controller

Controls stability at high mast heights is performed automatically. The SAS-Active Mast Front Tilt Angle Control limits forward tilt whenever a load is lifted past a preset mast height. The SAS-Active Mast Tilt Speed Control automatically reduces both forward and backward mast tilt speed whenever a load is lifted over 2,000 mm.



## High-Mounted Rear Combination Lights (OPT)

Easy-to-see and less likely to be damaged are just two of the benefits of these lights mounted high on the back of the overhead guard.



## Deadman Switch (OPT)

This switch shuts off the travel circuit when the operator is not on the seat, even when the key switch is in the "on" position. As long as the operator is not on the seat, the forklift will not move—even if the direction lever or accelerator is operated. In addition, if the operator is off of the forklift but has left the key switch in the "on" position, the Auto-Off System will shut off the power after 15 minutes to prevent wasting the charge in the battery.



## MAIN SPECIFICATIONS

Model		7FB10 (7FBH10)	7FB14 (7FBH14)	7FB15 (7FBH15)	40-7FB15	7FB18 (7FBH18)	7FB20 (7FBH20)	40-7FB20
Load Capacity	kg	1000	1350	1500	1500	1750	2000	2000
Load Center	mm	500	500	500	500	500	500	500
Overall Width	A mm	1060	1060	1115	1170	1115	1170	1150
Turning Radius (Outside)	B mm	1750	1760	1770	1980	1780	1980	2145
Overhead Guard Height	C mm	2025 (2105)	2025 (2105)	2025 (2105)	2105	2025 (2105)	2025 (2105)	2160
Length to Fork Face	D mm	2075	2080	2080	2216	2115	2240	2405

Model		7FB25 (7FBH25)	40-7FB25	7FB30	7FBJ35
Load Capacity	kg	2500	2500	3000	3500
Load Center	mm	500	500	500	500
Overall Width	A mm	1170	1150	1240	1240
Turning Radius (Outside)	B mm	2000	2170	2210	2270
Overhead Guard Height	C mm	2025 (2105)	2160	2195	2195
Length to Fork Face	D mm	2290	2435	2490	2575

## BATTERY AND MOTOR SPECIFICATIONS

Model			7FB10.14	7FB15.18	7FBH10.14 7FBH15.18	40-7FB15	7FB20	7FB25	7FBH20.25	40-7FB 20.25	7FB30 7FBJ35
Voltage/Capacity (5-hour ratings)	STD	V/AH	48/330	48/400	48/545	48/600	48/450	48/565	48/730	48/845	80/370
	High	V/AH	48/485	48/485	—	48/730	48/600	48/600	—	—	80/470
Electric Motors	Drive	kW	7.6	7.6	7.6	10.7	10.7	10.7	10.7	10.7	11.9
	Load Handling	kW	9.5	9.5	9.5	12.2	12.2	12.2	12.2	12.2	14.4
	Power Steering	kW	0.9	0.9	0.9	0.9	1.0	1.0	1.0	1.0	1.2

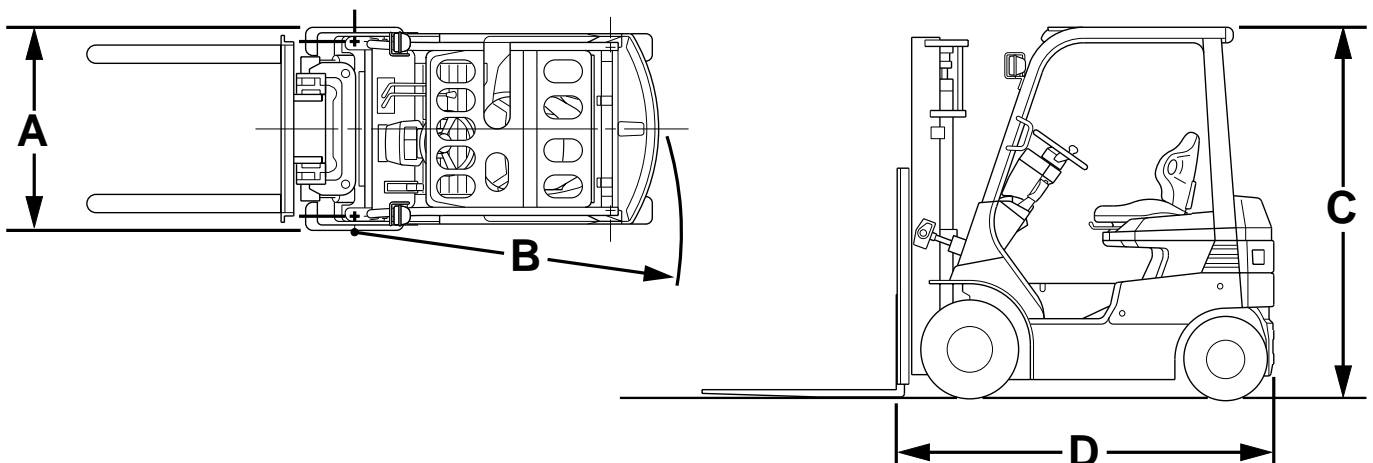

Features and equipment may vary depending on market.  
Availability and specifications are determined regionally and are subject to change without notice.  
Please consult your Toyota representative for details.

This brochure is printed on recycled paper with soy ink.  
All rights reserved by Toyota Industries Corporation.